

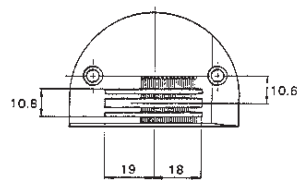

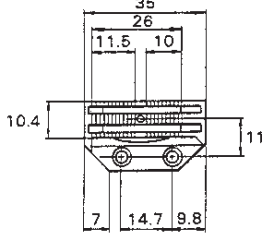







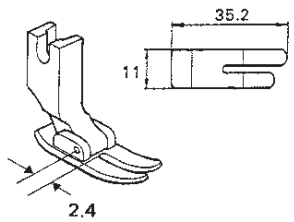
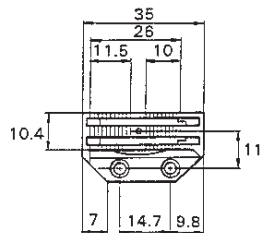

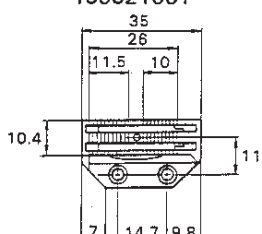

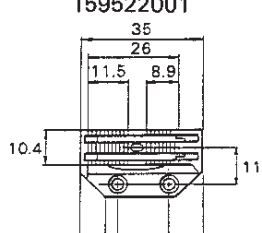
ゲージ部品一覧表/GAUGE PARTS LIST/LEHRENLISTE/
LISTE DE PIÉCES/LISTA DE PIEZAS CALIBRADORAS

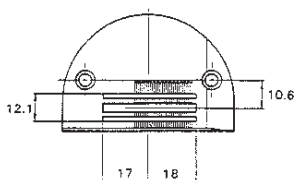
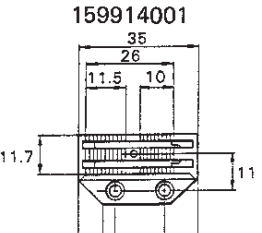
<B791>

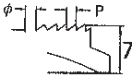
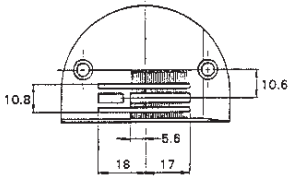
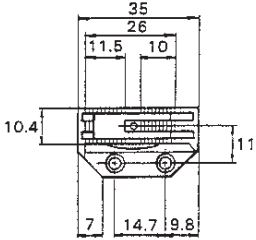

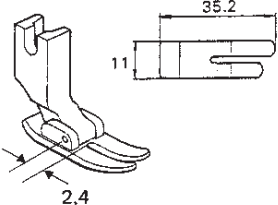
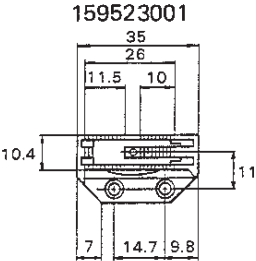
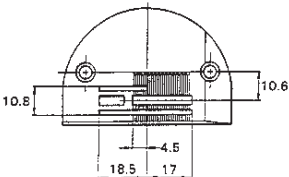
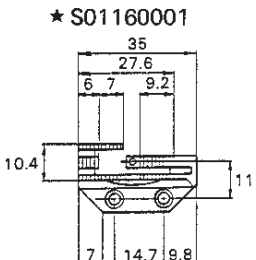

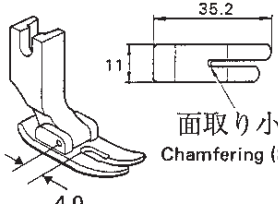
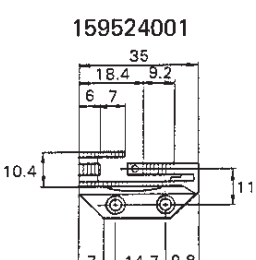
仕様 Sub-class	針板 Needle Plate  3.2	送り歯 Feed Dog	P		押工組 Presser Foot Assembly
			P	φ	
中厚物用 Medium-thick materials		★S01158001 	溝付 Slot		141158001 
		S03357001 		φ1.4	
		159521001 		φ2	
		159522001 		φ3.6	
		147954001 	159914001 		

- ★印は、スターダード専用の送り歯です。
糸切り用に使用すると、固定刃が送り歯にあたりますので使用しないで下さい。
- Parts marked with a star are feed dogs for standard machines only.
Use with thread trimming machines will cause the fixed knife to strike the feed dog. Avoid such use.
- Die mit einem Asteriskus bezeichneten Transporteure sind nur für standardmaschinen geeignet.
Bei Maschinen mit Fadenabschneider brüht das feststehende Messer den Transporteur.
- Les pièces portant une astérisque correspondent aux griffes d'entraînement pour les machines standard uniquement.
- Si elles sont utilisés avec une machine avec coupe-fils, le couteau fixe heurtera le griffe d'entraînement. Eviter une telle utilisation.
- Las piezas con asterisco corresponden a los alimentadores para máquinas de coser básicas.
Si se las usa en máquinas con cortahilos la cuchilla fija golpeará el alimentador. No se debe usar en estos casos.



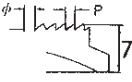
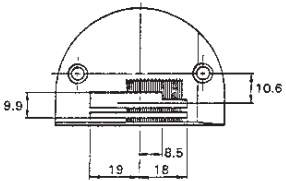
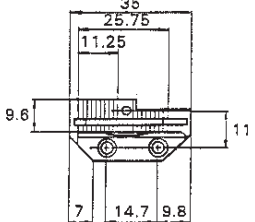

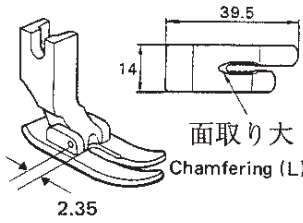
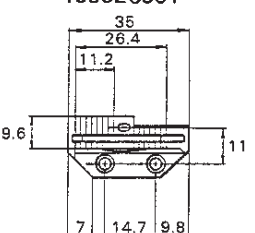
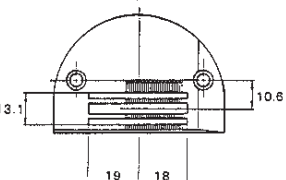
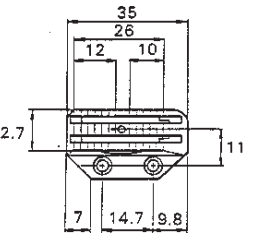
仕様 Sub-class	針板 Needle Plate  3.2	送り歯 Feed Dog 	押工組 Presser Foot Assembly	
			P	φ
中厚物用 Medium-thick materials	143857001 	★ S01159001 	溝付 Slot  φ2	141158001 
		159523001 		
	148300001 	★ S01160001 	溝付 Slot  φ2	147703001  面取り小 Chamfering (S)
		159524001 	φ2	

- ★印は、スターダード専用の送り歯です。
糸切り用に使用すると、固定刃が送り歯にあたりますので使用しないで下さい。
- Parts marked with a star are feed dogs for standard machines only.
Use with thread trimming machines will cause the fixed knife to strike the feed dog. Avoid such use.
- Die mit einem Asteriskus bezeichneten Transporteure sind nur für Standardmaschinen geeignet.
Bei Maschinen mit Fadenabschneider brührt das feststehende Messer den Transporteur.
- Les pièces portant une astérisque correspondent aux griffes d'entraînement pour les machines standard uniquement.
Si elles sont utilisés avec une machine avec coupe-fils, le couteau fixe heurtera le griffe d'entraînement. Eviter une telle utilisation.
- Las piezas con asterisco corresponden a los alimentadores para máquinas de coser básicas.
Si se las usa en máquinas con cortahilos la cuchilla fija golpeará el alimentador. No se debe usar en estos casos.



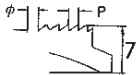
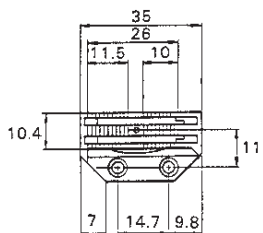

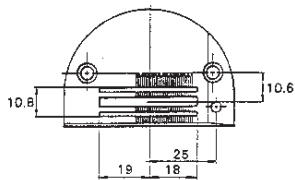
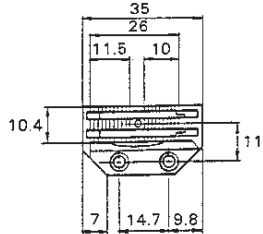

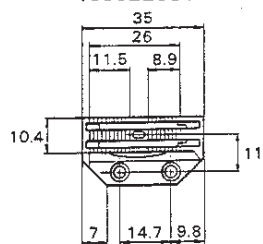
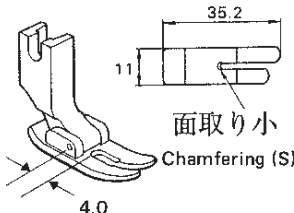
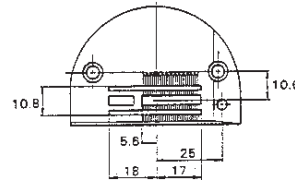
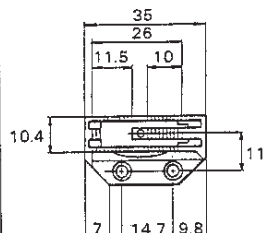
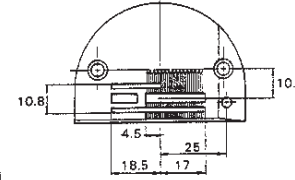
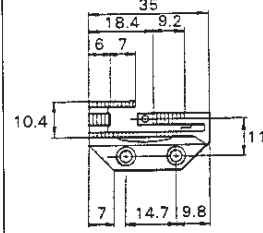

<B791>

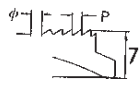
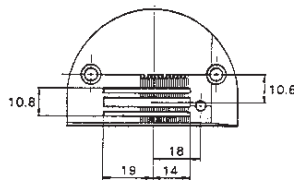
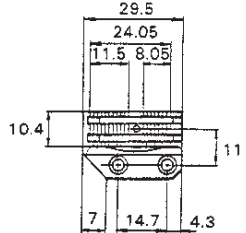
仕様 Sub-class	針板 Needle Plate  3.2	送り歯 Feed Dog			押工組 Presser Foot Assembly
			P	φ	
厚物用 Thick materials	148842001 	159525001 	1.25	 φ2.8	140717001  面取り大 Chamfering (L)
		159526001 			
	S13101001 	S13102001 	2	 φ2.4	

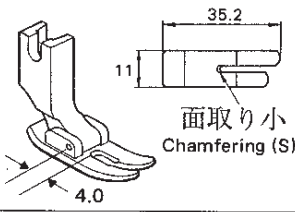
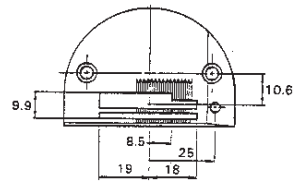
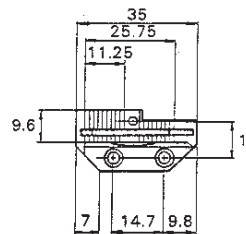
<B7910>

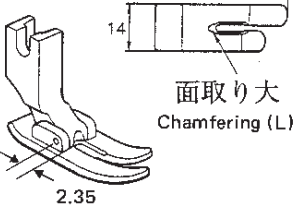
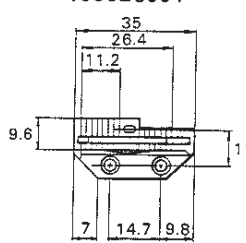
仕様 Sub-class	針板 Needle Plate  3.2	送り歯 Feed Dog 	押工組 Presser Foot Assembly	
			P	φ
中厚物用 Medium-thick materials		S03357001 	1.15	 φ1.4
	S11156001 	159521001 		 φ2
		159522001 	 面取り小 Chamfering (S)	
	S11157001 	159523001 	φ2	
	S11159001 	159524001 		

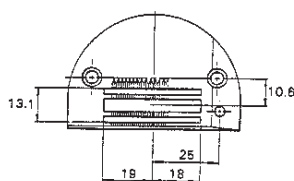
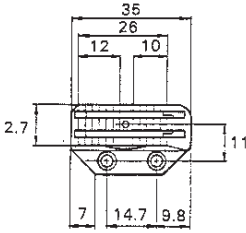
<B7910>

仕様 Sub-class	針板 Needle Plate  3.2	送り歯 Feed Dog 			押工組 Presser Foot Assembly
			P	φ	
中厚物用 Medium-thick materials	S11463001 	S11464001 	1.15	 φ2	147703001  面取り小 Chamfering (S)
厚物用 Thick materials	S11158001 	159525001 	1.25	 φ2.8	140717001  面取り大 Chamfering (L)
		159526001 	1.6	 φ3.6	
	S11160001 	S13102001 	2	 φ2.4	